

## "LAZUR M-100". TECHNICAL DATA

<b>2.1. Quality indicators of the feed water:</b>	<b>Drinking / Waste water*</b>
2.1.1. Suspended solids, mg/l, no more than	(1)* / 10
2.1.2. UV Transmittance at 254 nm for 10-mm water column, %	(85)* / 60
2.1.3. Colour, degree, no more than	(20)* / 50
2.1.4. Turbidity, NTU, no more than	(1÷2)* / 3
2.1.5. Iron content, mg/l, no more than	0,3
2.1.6. Temperatures of water under treatment and of ambient air, °C	+4 ÷ +30
2.1.7. Total Bacteria Count in 1 litre, no more than	(1000)* / 5...10 <sup>6</sup>
2.1.8. Coliphages, no more than	(100)* / 5...10 <sup>4</sup>
<b>2.2. Quality indicators of the treated water:</b>	
2.2.1. Total Bacteria Count in 100 ml, no more than	(50)* / 100
2.2.2. Coliphages (MS2), in 100 ml, no more than	(absent)* / 100
<b>2.3. Minimal dose of UV irradiation, not less than, mJ/cm<sup>2</sup></b>	<b>40 (65)**</b>
<b>2.4. Nominal flowrate, m<sup>3</sup>/h</b>	<b>100</b>
<b>2.5. Minimal service life of UV amalgam lamps, hours</b>	<b>16000</b>
<b>2.6. Minimal flow of water in the working system, l/hour</b>	<b>130</b>
<b>2.7. Power source (AC) nominal, 50Hz</b>	<b>220±10%</b>
<b>2.8. Maximum power consumption, kWh</b>	<b>2,7</b>

2.9.	Minimal working pressure in the feeding water pipe $P_{\min}$ Atm	0,2
2.10.	Maximum working pressure in the feeding water pipe $P_{\max}$ Atm	4,0
2.11.	Pressure loss at nominal flow rate, meters of water column, less than	0,25
2.12.	Protection rating of the Control Panel	IP55
2.13.	Minimal time required to reach optimal working parameters, min	5
2.14.	Time required between switching off and switching on of the system, min, no less than	10
2.15.	Disinfection unit dimensions, mm	492x1612x1136
2.16.	Control panel dimensions, mm	1000x600x250
2.17.	Total weight of the system, kg	120
2.18.	Photochemical reactor volume, litres	67
2.19.	Feeding pipe diameter, depending on the PCR type:	
2.19.1.	PCR100.100	Ø100
2.19.2.	PCR100.150	Ø150
2.20.	Maximum noise level on A-weighting scale at a distance of 2 meters, no more than	78 dB

\*) In systems for drinking water disinfection

\*\*) In systems with amalgam lamps

### **Figure 1. General view and set up plan for Lazur M-100 system**

1. Photochemical Reactor; 2. Control Panel; 3. UV lamp;
4. Protective quartz sleeve; 5. Hermetic coupling; 6. Protective cap;
7. Support; 8. Ultrasound Emitter; 9. Earthing terminal;
10. Drain pipe; 11. Sampling Port; 12. Cabinet; 13. UV monitor (optional);

Decimal Number	Diameter of Pipe A, mm
PCR 100.100	100
PCR 100.150	150

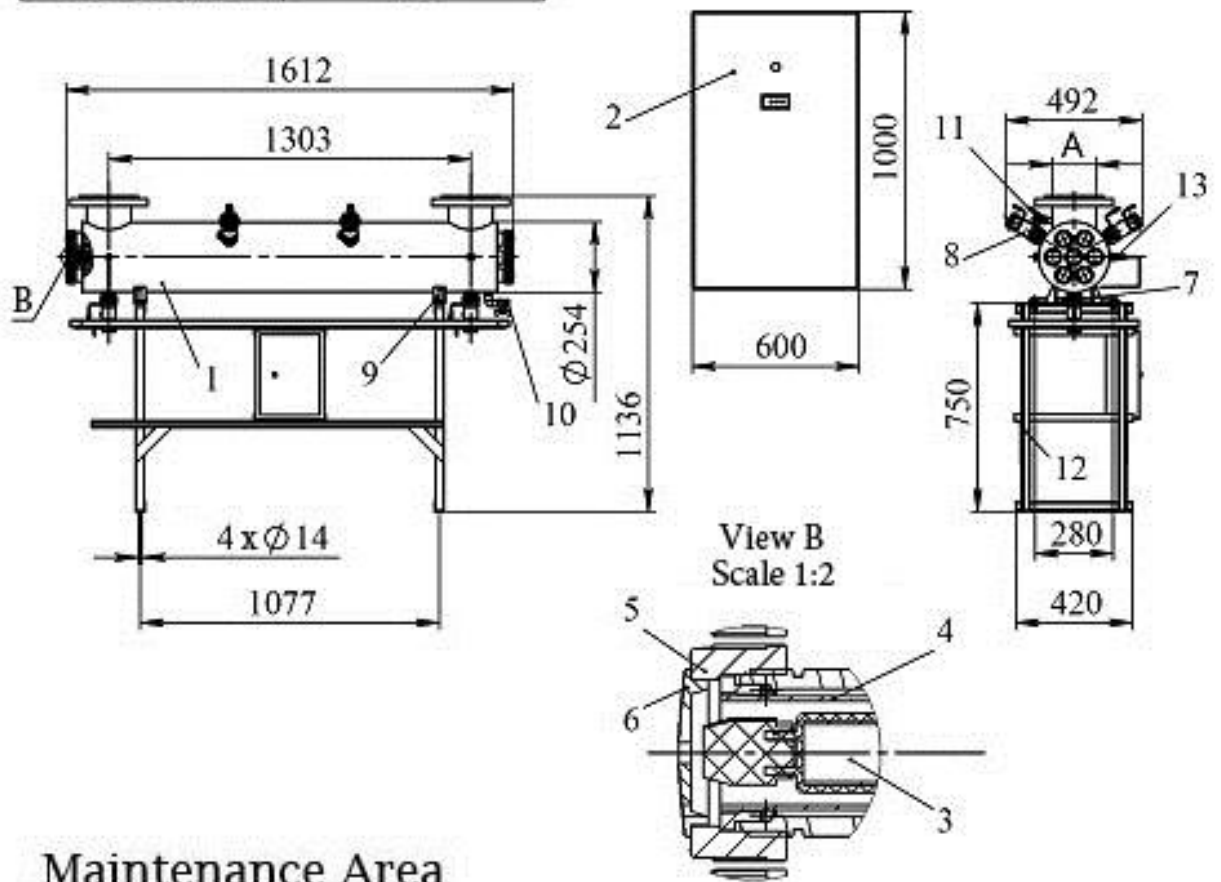

### Maintenance Area

